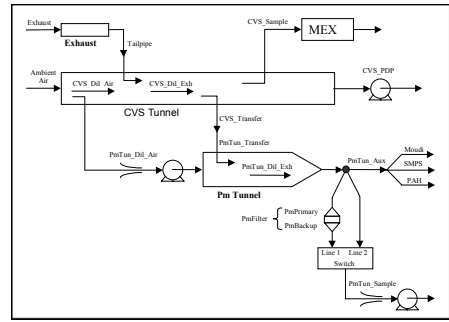


# DETR Summary Report

## Figures

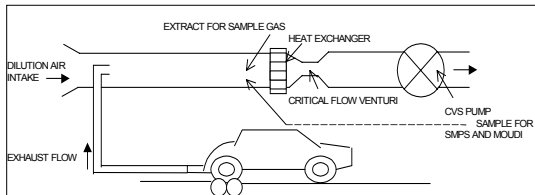
### Figure 1

SAE 2000-01-2850



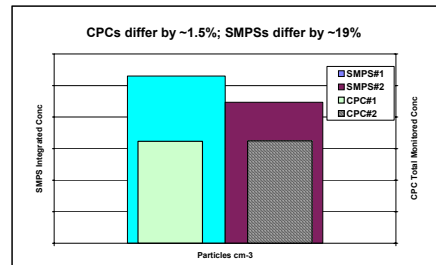
### Figure 2

drawing



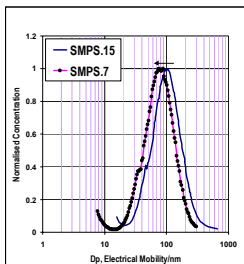
### Figure 3

3range



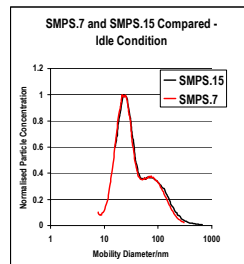
### Figure 4

3range



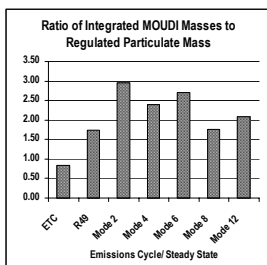
### Figure 5

Golf\_Idle



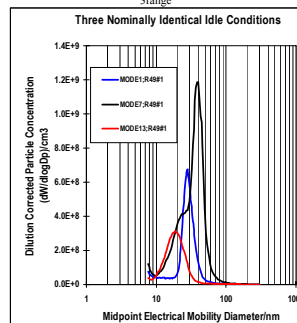
### Figure 6

NIMsETCdata



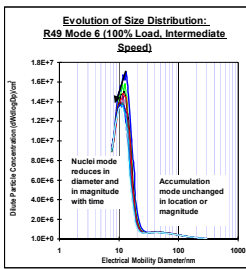
### Figure 7

3range

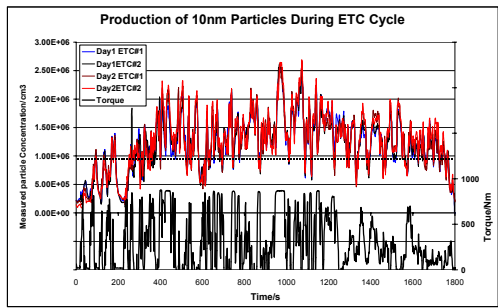


### Figure 8

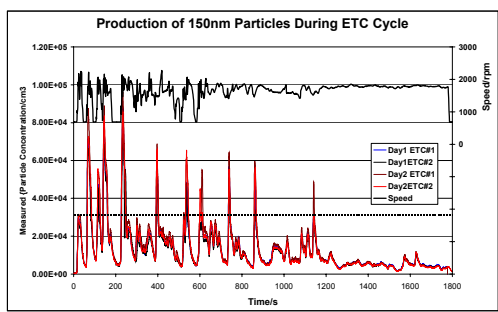
R49mode/evolution



### Figure 9



### Figure 10



### Figures 11 and 12

from r621v1hs

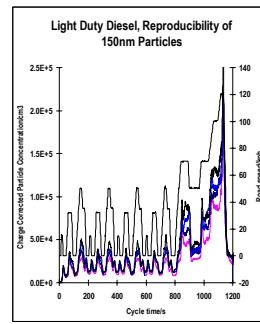
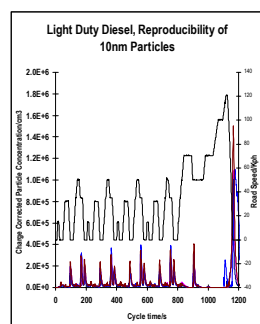


Figure 13a

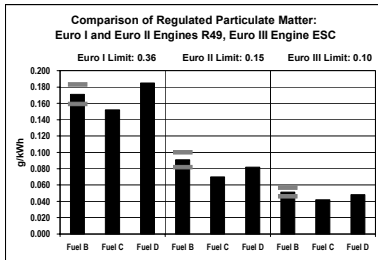
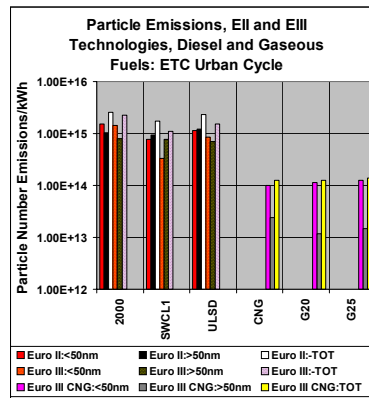
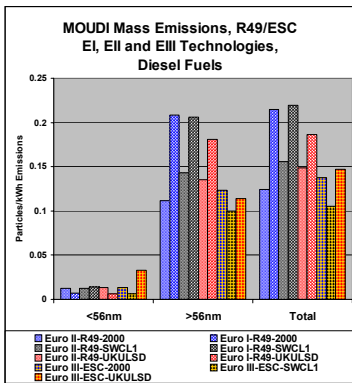
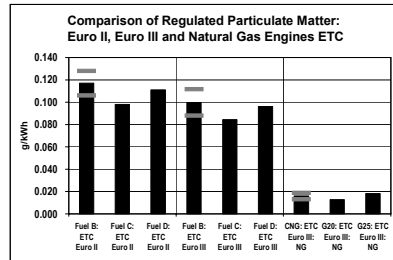


Figure 13b



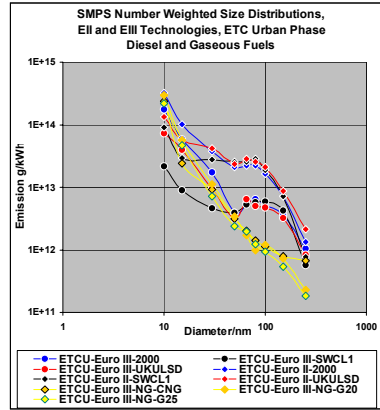
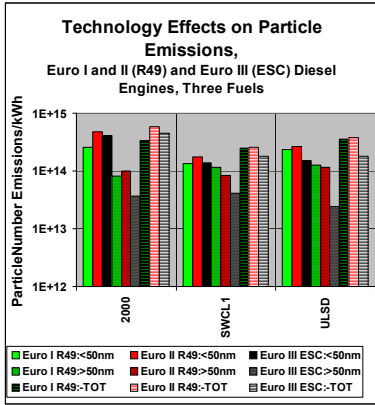
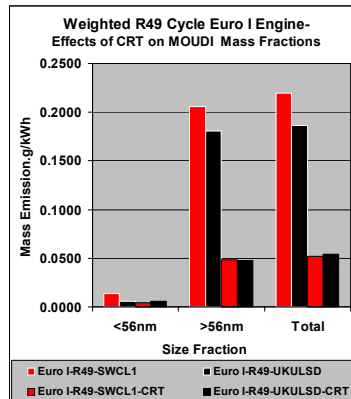
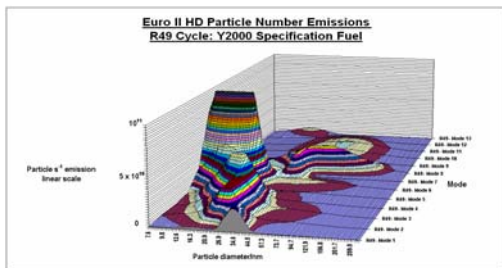
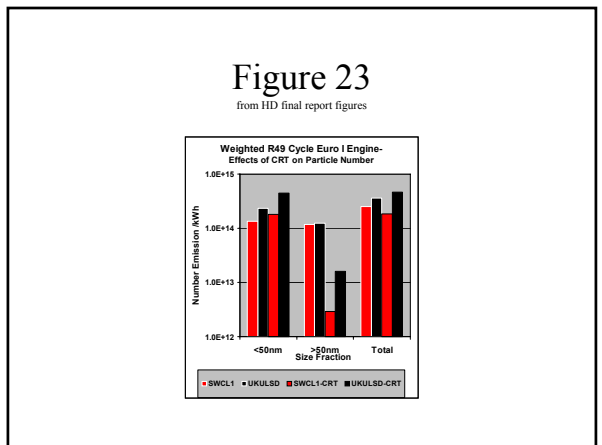
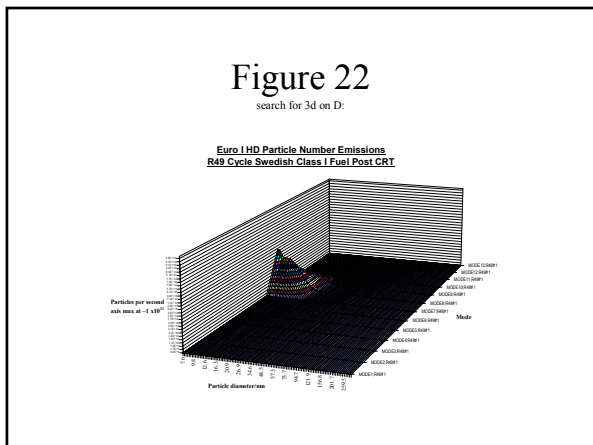
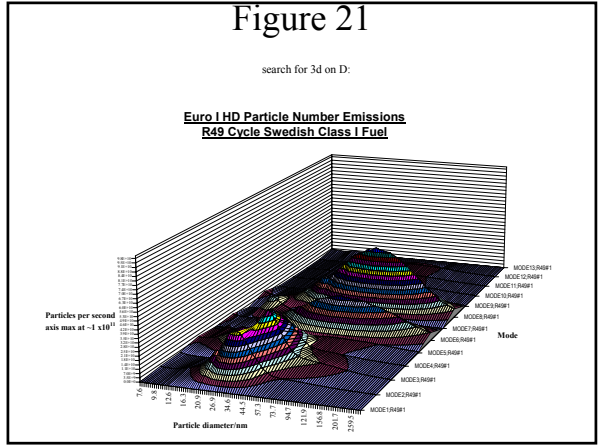
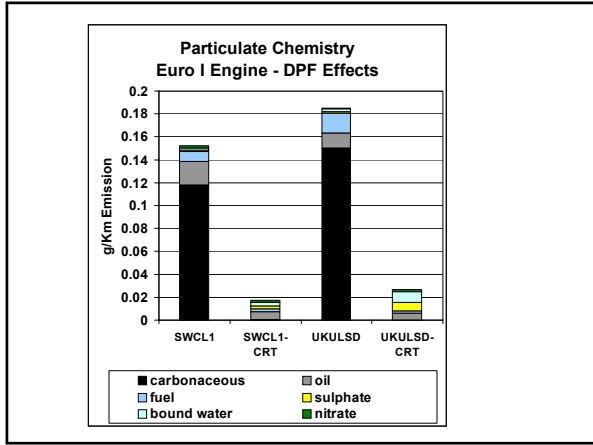


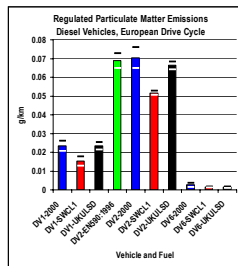
Figure 18

from BW2dand3d R49

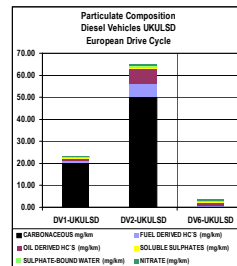




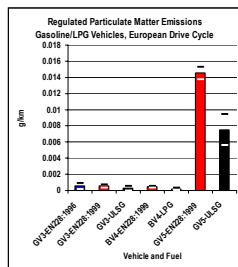
**Figure 24**  
from PM-all vehicle results



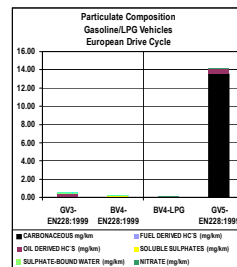
**Figure 25**  
from LD Chem



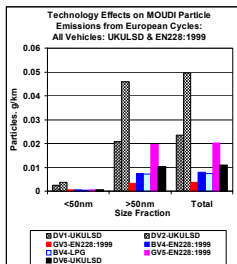
**Figure 26**  
from PM-all vehicle results



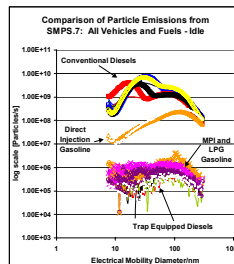
**Figure 27**  
from LD Chem



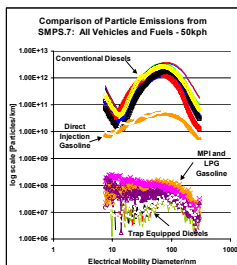
**Figure 28**  
from non grey LD figures



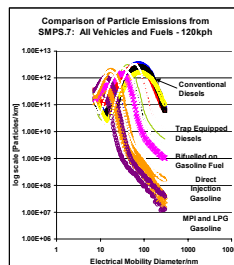
**Figure 29**  
from non grey..



**Figure 30**  
from non grey..



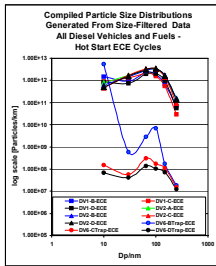
**Figure 31**  
from non grey





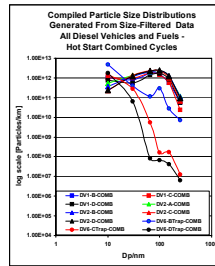
### Figure 32

from non grey



### Figure 33

from non grey



### Figure 34

from LD Technology figures

